



BAR KNOBS

THERMOPLASTIC

Material- Call for material specifications

Insert- Brass

Projecting Stud- Steel, zinc plated

Hex Nut- Steel, zinc plated

† Insert- Steel, zinc plated

* Insert- Aluminum



3081



3084



3088/3089 Thru Hole



3086



3087



3088/3094



3093



3096



2031



2031



2033



2020



2022

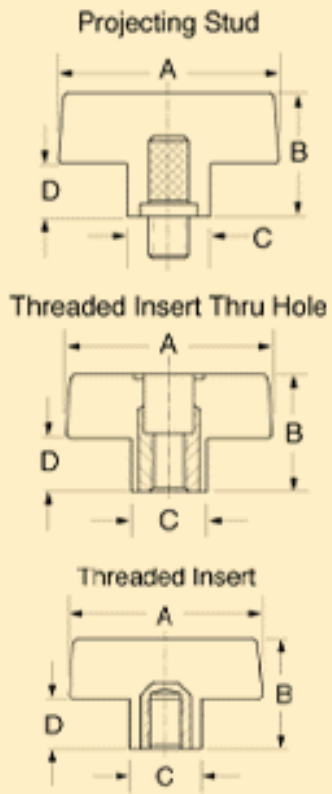

Threaded Insert

Part No.	Insert	
	Thread	Depth
3081-AE	8 x 1.25	12.7
3081-A	5/16-18	1/2
3081-B	3/8-16	1/2
3081	1/4-20	1/2

[← back](#)